

Technical sheet :

# **MI 35 D**

---



Technical characteristics			Metric	Imperial
1.1	Manufacturer		Manitou	Manitou
1.2	Model Name		MI 35 D	MI 35 D
1.3	Power source		Diesel	Diesel
1.4	Operator type		Seated	Seated
1.5	Max. capacity	Q	3500 kg	7716 lbs
1.6	Load centre of gravity	c	500 mm	19.685 in
1.8	Load distance, centre of drive axle to fork	x	485 mm	19.094 in
1.9	Wheelbase	y	1700 mm	66.929 in
Weight				
2.1	Service Weight		4860 kg	10714 lbs
2.2	Weight on front axle (laden) / rear axle (laden)		7360 kg / 1000 kg	16226 lbs / 2205 lbs
2.3	Weight on front axle (Unladen) / rear axle (Unladen)		1825 kg / 3035 kg	4023 lbs / 6691 lbs
Wheels				
3.1	Tyres type		PPS	PPS
3.2	Dimensions of front wheels		28-9-1512	28-9-1512
3.3	Dimensions of rear wheels		6.50-10 10	6.50-10 10
3.5	Number of front wheels / rear wheels		2 / 2	2 / 2
3.2	Number of drive wheels		2	2
3.6	Front wheel gauge	b10	1005 mm	39.567 in
3.7	Rear wheel gauge	b11	975 mm	38.386 in
Dimensions				
4.1	Tilt of Mast Forward (deg) / Backward (deg)	$\alpha / \beta$	6 / 12	6 / 12
4.7	Height of overhead guard (cabin)	h6	2130 mm	83.858 in
4.8	Seat height/stand height	h7	1215 mm	47.835 in
4.12	Height of towing bar (coupling height)	h10	360 mm	14.173 in
4.19	Overall length	l1	3935 mm	154.921 in
4.20	Length to face of forks	l2	2785 mm	109.646 in
4.21	Overall width	b1	1225 mm	48.228 in
4.22	Forks section / width / length	s / e / l	50 mm x 122 mm x 1150 mm	1.969 in x 4.803 in x 45.276 in
4.23	Fork carriage ISO 2328 (class/form) A/B		3A	3A
4.24	Fork carriage width	b3	1100 mm	43.307 in
4.31	Ground clearance below mast	m1	130 mm	5.118 in
4.32	Ground clearance at centre of wheelbase	m2	200 mm	7.874 in
4.33	Aisle width for 1000 x 1200 pallet widthways	Ast	4195 mm	165.157 in
4.34	Aisle width for 800 x 1200 pallet lengthways	Ast	4395 mm	173.031 in
4.36	Internal turning radius (over tyres)	b13	160 mm	6.299 in
Performances				
5.1	Travel speed (laden / unladen)		18 km/h / 18.5 km/h	11.2 mph / 11.5 mph
5.2	Lifting speed (laden / unladen)		0.39 m/s / 0.4 m/s	1.28 ft/s / 1.31 ft/s
5.3	Lowering speed (laden / unladen)		0.4 m/s / 0.35 m/s	1.31 ft/s / 1.15 ft/s
5.5	Drawbar pull (Laden / Unladen)		1830 daN / 1520 daN	1830 daN / 1520 daN
5.7	Gradeability - laden / unladen		18 % / 20 %	18 % / 20 %
5.9	Service brake		Hydraulic	Hydraulic
Engine				

	Engine			
7.1	Engine brand / model / norm		Yanmar / 4TNV94L-BXPHZ / Stage 3A	Yanmar / 4TNV94L-BXPHZ / Stage 3A
7.2	Engine power according to ISO 1585		35 kW	35 kW
7.3	Rated speed		2400 tr/min	2400 tr/min
7.4	Number of cylinders / Capacity of cylinders		4 - 3054 cm <sup>3</sup>	4 - 186.37 in <sup>3</sup>
	Fuel consumption according to VDI cycle		3.56 l/h	3.56 l/h
Miscellaneous				
8.2	Working hydraulic pressure for attachments (bar)		160 Bar	11 PSI
8.3	Oil flow rate for attachments		69 l/min	69 l/min
8.4	Measured/guaranteed mean noise level at the ear of the operator		< 84 dB(A)	< 84 dB(A)

## Dimensional drawing

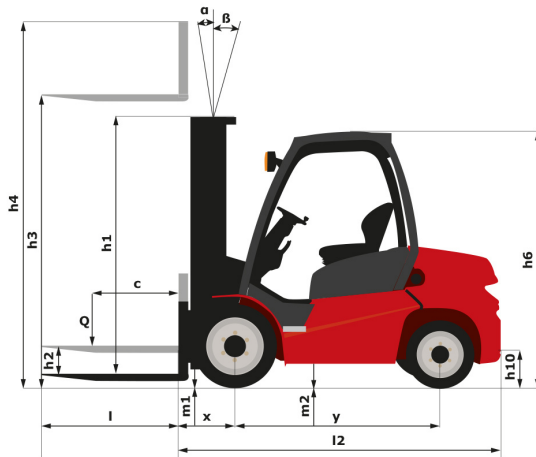

## Characteristics of masts and residual capacities

Full Visibility Duplex		FVD 33	FVD 37	FVD 40
h2 - Free lift	mm	145	145	145
h1 - Height mast Lowered	mm	2315	2565	2715
h3 - Lifting Height	mm	3300	3700	4000
h4 - Height mast extended	mm	4115	4515	4815
$\alpha / \beta$ - Mast inclination (front / rear)	°	6 / 12	6 / 12	6 / 12
Residual capacity without attachment (Industrial load chart)	kg	3500	3500	3500
Residual capacity with integrated side shift (Industrial load chart)	kg	3500	3500	3500
Height at max capacity	mm	3300	3700	4000
Height at max capacity with integrated sideshift	mm	3300	3700	4000
Height at max capacity Fork positioner + DL	mm	3300	3700	4000

Free Lift Duplex		FLD 33	FLD 37	FLD 40
h2 - Free lift	mm	1500	1700	1850
h1 - Height mast Lowered	mm	2330	2530	2680
h3 - Lifting Height	mm	3300	3700	4000
h4 - Height mast extended	mm	4130	4530	4830
$\alpha / \beta$ - Mast inclination (front / rear)	°	6 / 12	6 / 12	6 / 12
Residual capacity without attachment (Industrial load chart)	kg	3500	3500	3500
Residual capacity with integrated side shift (Industrial load chart)	kg	3500	3500	3500
Height at max capacity	mm	3300	3700	4000
Height at max capacity with integrated sideshift	mm	3300	3700	4000
Height at max capacity Fork positioner + DL	mm	3300	3700	

Free Lift Triplex		FLT 43	FLT 45	FLT 47	FLT 48	FLT 50	FLT 55	FLT 60	FLT 65
h2 - Free lift	mm	1385	1435	1485	1535	1585	1735	1985	2135
h1 - Height mast Lowered	mm	2215	2265	2315	2365	2415	2565	2815	2965
h3 - Lifting Height	mm	4300	4500	4700	4800	5000	5500	6000	6500
h4 - Height mast extended	mm	5130	5380	5530	5630	5830	6330	6880	7330
$\alpha / \beta$ - Mast inclination (front / rear)	°	6 / 6	6 / 6	6 / 6	6 / 6	6 / 6	3 / 6	3 / 6	3 / 6

Free Lift Triplex		FLT 43	FLT 45	FLT 47	FLT 48	FLT 50	FLT 55	FLT 60	FLT 65
Residual capacity without attachment (Industrial load chart)	kg	3450	3400	3300	3300	3000	2200	1600	1500
Residual capacity with integrated side shift (Industrial load chart)	kg	3450	3300	3200	3200	2900	2100	1500	1400
Height at max capacity	mm	4000	4000	4000	4000	4000	4000	4000	4000
Height at max capacity with integrated sideshift	mm	4000	4000	4000					
Height at max capacity Fork positioner + DL	mm	4000	4000						

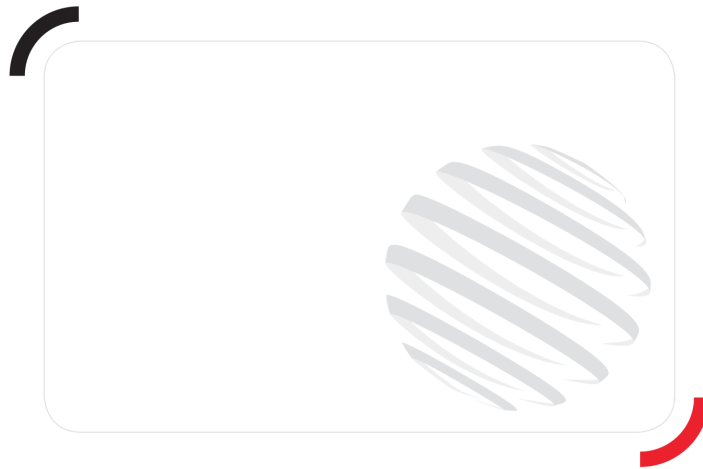

Siège Social

430 rue de l'Aubinière - 44150 Ancenis Cedex - France

Tel: +33(0)2 40 09 10 11 - Fax: +33 (0)2 40 09 10 97

[www.manitou.com](http://www.manitou.com)



This brochure describes versions and configuration options for Manitou products which may be fitted with different equipment. The equipment described in this brochure may be standard, optional or not available depending on version. Manitou reserves the right to change the specifications shown and described at any time and without prior warning. The manufacturer is not liable for the specifications given. For more information, contact your Manitou dealer. Non-contractual document. Product descriptions may differ from actual products. List of specifications is not comprehensive. The logos and visual identity of the company are the property of Manitou and may not be used without authorisation. All rights reserved. The photos and diagrams contained in this brochure are provided for information only.

MANITOU BF SA - Limited company with board of directors - Share capital: 39,668,399 euros - 857 802 508  
RCS Nantes