

Technical sheet :

ES 507 GPF - ES-C 507



Technical characteristics			Metric	Imperial
1.1	Manufacturer		Manitou	Manitou
1.2	Model Name		ES 507 GPF - ES-C 507	ES 507 GPF - ES-C 507
1.3	Power source		Battery	Battery
1.4	Operator type		Pedestrian	Pedestrian
1.5	Max. capacity	Q	700 kg	1543 lbs
1.6	Load centre of gravity	c	400 mm	15.748 in
1.8	Distance from Load backrest to center of rear axle	x	101 mm	3.976 in
1.9	Wheelbase	y	932 mm	36.693 in
Weight				
2.1	Service Weight		1250 kg	2756 lbs
2.2	Weight on front axle (laden) / rear axle (laden)		1893 kg / 307 kg	4173 lbs / 677 lbs
2.3	Weight on front axle (Unladen) / rear axle (Unladen)		820 kg / 680 kg	1808 lbs / 1499 lbs
Wheels				
3.1	Tyres type		Polyurethane	Polyurethane
3.2	Number of drive wheels - Size of drive wheels		1 x 230x70	1 x 230x70
3.3	Number of load wheels - Size of load wheels		2 x 150x70	2 x 150x70
3.5	Number of front wheels / rear wheels		1 / 2	1 / 2
3.7	Rear wheel gauge	b11	826 mm	32.52 in
Dimensions				
4.2	Mast height lowered	h1	1931 mm	76.024 in
4.4	Mast lifting height	h3	2850 mm	112.205 in
4.5	Mast height extended	h4	3500 mm	137.795 in
4.9	Height tiller up min./max. / max.	h14 / h14	830 mm / 1385 mm	32.677 in / 54.528 in
4.15	Fork height in low position	h13	35 mm	1.378 in
4.19	Overall length	l1	2013 mm	79.252 in
4.20	Length to face of forks	l2	1213 mm	47.756 in
4.21	Overall width	b1	923 mm	36.339 in
4.22	Forks section / width / length	s / e / l	30 mm x 90 mm x 800 mm	1.181 in x 3.543 in x 31.496 in
4.23	Fork carriage ISO 2328 (class/form) A/B		2B	2B
4.24	Fork carriage width	b3	750 mm	29.528 in
4.31	Ground clearance below mast	m1	60 mm	2.362 in
4.32	Ground clearance at centre of wheelbase	m2	69 mm	2.717 in
4.34	Aisle width for 800 x 1200 pallet lengthways	Ast	2891 mm	113.819 in
4.35	Turning radius	Wa	1335 mm	52.559 in
Performances				
5.1	Travel speed (laden / unladen)		4.5 km/h / 4.5 km/h	2.8 mph / 2.8 mph
5.2	Lifting speed (laden / unladen)		0.3 m/s / 0.18 m/s	0.98 ft/s / 0.59 ft/s
5.3	Lowering speed (laden / unladen)		0.22 m/s / 0.27 m/s	0.72 ft/s / 0.89 ft/s
5.7	Gradeability - laden / unladen		7 % / 10 %	7 % / 10 %
5.9	Service brake		Electro magnetic	Electro magnetic
Engine				
6.1	Drive motor rating S2 60 min		1.5 kW	1.5 kW
6.2	Lift motor rating at S3 15%		3 kW	3 kW

	Engine			
6.3	Battery according to DIN 43531/35/36 A, B, C		DIN 43535-B	DIN 43535-B
6.4	Battery / Batteries capacity		24 V - 180 Ah	24 V - 180 Ah
6.5	Battery weight (+/- 5%)		189 kg	417 lbs
	Miscellaneous			
8.1	Type of drive control		AC	AC
8.4	Sound level at the driver's ear according to DIN 12 053		65 dB(A)	65 dB(A)

Dimensional drawing

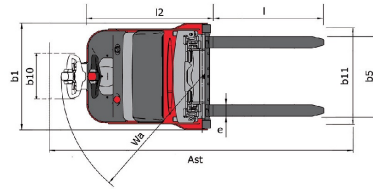
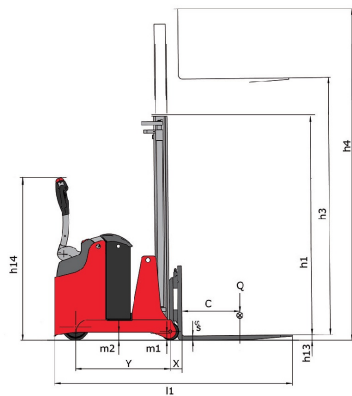

Characteristics of masts and residual capacities

Central Cylinder Simplex		CCS 15	CCS 17
h2 - Free lift	mm	1420	1670
h1 - Height mast Lowered	mm	1931	2181
h3 - Lifting Height	mm	1420	1670
h4 - Height mast extended	mm	2070	2320
Residual capacity without attachment (Industrial load chart)	kg	700	700

Full Visibility Duplex		FVD 29	FVD 34	FVD 38
h1 - Height mast Lowered	mm	1931	2181	2381
h3 - Lifting Height	mm	2850	3350	3750
h4 - Height mast extended	mm	3500	4000	4400
Residual capacity without attachment (Industrial load chart)	kg	700	700	600

Free Lift Duplex		FLD 29	FLD 34
h2 - Free lift	mm	1420	1670
h1 - Height mast Lowered	mm	1931	2181
h3 - Lifting Height	mm	2850	3350
h4 - Height mast extended	mm	3500	4000
Residual capacity without attachment (Industrial load chart)	kg	700	700

Free Lift Triplex		FLT 42
h2 - Free lift	mm	1380
h1 - Height mast Lowered	mm	1956
h3 - Lifting Height	mm	4160
h4 - Height mast extended	mm	4810
Residual capacity without attachment (Industrial load chart)	kg	500



Siège Social

430 rue de l'Aubinière - 44150 Ancenis Cedex - France

Tel: +33(0)2 40 09 10 11 - Fax: +33 (0)2 40 09 10 97

www.manitou.com



This brochure describes versions and configuration options for Manitou products which may be fitted with different equipment. The equipment described in this brochure may be standard, optional or not available depending on version. Manitou reserves the right to change the specifications shown and described at any time and without prior warning. The manufacturer is not liable for the specifications given. For more information, contact your Manitou dealer. Non-contractual document. Product descriptions may differ from actual products. List of specifications is not comprehensive. The logos and visual identity of the company are the property of Manitou and may not be used without authorisation. All rights reserved. The photos and diagrams contained in this brochure are provided for information only.

MANITOU BF SA - Limited company with board of directors - Share capital: 39,668,399 euros - 857 802 508
RCS Nantes