

Technical sheet :

MC 25-4 ST5



Technical characteristics			Metric	Imperial
1.1	Manufacturer		Manitou	Manitou
1.2	Model Name		MC 25-4 ST5	MC 25-4 ST5
1.3	Power source		Diesel	Diesel
1.4	Operator type		Seated	Seated
1.5	Max. capacity	Q	2500 kg	5512 lb
1.6	Load center of gravity	c	500 mm	20 in
1.8	Load distance, centre of drive axle to fork	x	621 mm	24 in
1.9	Wheelbase	y	1900 mm	75 in
Weight				
	Standard mast reference of the machine		FVD 33	FVD 33
2.1	Service weight		4290 kg	9458 lb
2.2	Weight on front axle (laden) / rear axle (laden)		5970 kg / 820 kg	13162 lb / 1808 lb
2.3	Weight on front axle (Unladen) / rear axle (Unladen)		1780 kg / 2510 kg	3924 lb / 5534 lb
Wheels				
3.1	Tires type		Pneumatic	Pneumatic
3.2	Dimensions of front wheels		12,5/80-18/12 SL R4	12,5/80-18/12 SL R4
3.3	Dimensions of rear wheels		27x10-12 SKS	27x10-12 SKS
3.5	Number of front wheels / rear wheels		2 / 2	2 / 2
3.5.2	Number of drive wheels		4	4
3.6	Front wheel gauge	b10	1159 mm	46 in
3.7	Rear wheel gauge	b11	1176 mm	46 in
Dimensions				
4.7	Height of overhead guard (cabin) / Overall height of low overhead guard (Buggie version)	h6 / h6*	2155 mm / 1990 mm	85 in / 78 in
4.8	Seat height/stand height	h7	1094 mm	43 in
4.19	Overall length	l1	4195 mm	165 in
4.20	Length to face of forks	l2	3045 mm	120 in
4.21	Overall width	b1	1450 mm	57 in
4.22	Forks section x width x length	s / e / l	40 mm x 100 mm / 1200 mm	2 in x 4 in / 47 in
4.23	Fork carriage ISO 2328 (class/form) A/B		2A	2A
4.24	Fork carriage width	b3	1260 mm	50 in
4.31	Ground clearance below mast	m1	300 mm	12 in
4.32	Ground clearance at centre of wheelbase	m2	310 mm	12 in
4.35	Turning radius	Wa	3405 m	11171 ft 3 in
Performances				
5.1	Travel speed (laden / unladen)		12 km/h / 24.50 km/h	7 mph / 15 mph
5.2	Lifting speed (laden / unladen)		0.47 m/s / 0.46 m/s	2 ft/s / 2 ft/s
5.3	Lowering speed (laden / unladen)		0.50 m/s / 0.30 m/s	2 ft/s / 0.98 ft/s
5.5	Drawbar pull (Laden)		3100 daN	3100 daN
5.7	Gradeability (laden)		51 %	51 %
5.10	Service brake		Hydraulic brakes by loss of pressure	Hydraulic brakes by loss of pressure
Engine				
7.2	I.C. Engine power rating		37 kW	37 kW
7.1	Engine brand / model / nom		Kubota / D1803 CRT E5B / Stage V	Kubota / D1803 CRT E5B / Stage V
7.3	Rated speed		2700 rpm	2700 rpm
7.4	Number of cylinders / Capacity of cylinders		3 - 1826 cm ³	3 - 111 in ³
Miscellaneous				
8.1	Type of drive control		Electronic	Electronic
8.2	Working hydraulic pressure for attachments		200 bar	2901 PSI
8.3	Oil flow rate for attachments		42 l/min	11 US gpm

MC 25-4 ST5 - Dimensional drawing

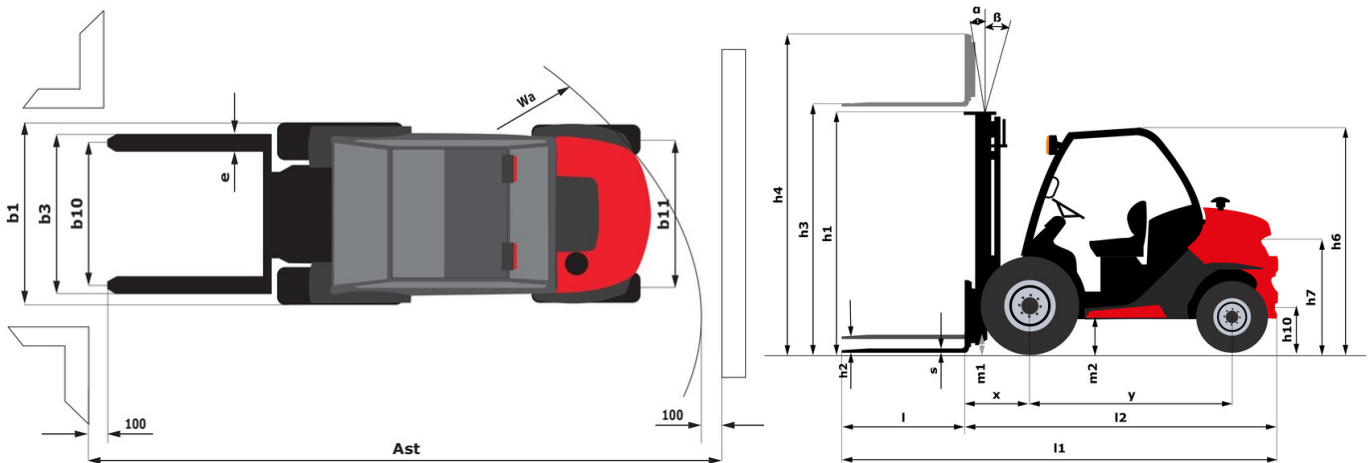

Characteristics of masts and residual capacities

Full Visibility Duplex (FVD)		FVD 33	FVD 37	FVD 45
α - Mast/fork carriage tilt, forward	°	12	12	12
β - Mast/fork carriage tilt, backward	°	10	10	10
h1 - Mast lowered height	in (mm)	92 (2338)	102.3 (2598)	119.6 (3038)
h2 - Mast free lift	in (mm)	4.4 (112)	4.4 (112)	4.4 (112)
h3 - Mast lifting height	in (mm)	129.9 (3300)	145.7 (3700)	177.2 (4500)
h4 - Mast extended height	in (mm)	161 (4090)	176.8 (4490)	208.3 (5290)
Residual capacity at max height	lb (kg)	5512 (2500)	3197 (1450)	1764 (800)
Residual capacity with hooked-on side shift at max height	lb (kg)	5512 (2500)	3197 (1450)	1764 (800)
Height at max capacity	in (mm)	118.1 (3000)	118.1 (3000)	118.1 (3000)
Height at max capacity with hooked-on sideshift	in (mm)	118.1 (3000)	118.1 (3000)	118.1 (3000)

Free Lift Triplex (FLT)		FLT 34	FLT 37	FLT 40	FLT 43	FLT 47	FLT 55
α - Mast/fork carriage tilt, forward	°	12	12	12	12	12	6
β - Mast/fork carriage tilt, backward	°	10	10	10	10	10	6
h1 - Mast lowered height	in (mm)	78.3 (1988)	82.2 (2088)	86.1 (2188)	92 (2338)	96 (2438)	109.8 (2788)
h2 - Mast free lift	in (mm)	47.6 (1210)	51.6 (1310)	55.5 (1410)	59.4 (1510)	65.4 (1660)	75.6 (1920)
h3 - Mast lifting height	in (mm)	133.9 (3400)	145.7 (3700)	157.5 (4000)	169.3 (4300)	185 (4700)	216.5 (5500)
h4 - Mast extended height	in (mm)	166.8 (4236)	178.6 (4536)	190.4 (4836)	203.5 (5168)	218 (5536)	252.3 (6408)
Residual capacity at max height	lb (kg)	4189 (1900)	3307 (1500)	2976 (1350)	1764 (800)	1543 (700)	1102 (500)
Residual capacity with hooked-on side shift at max height	lb (kg)	3968 (1800)	3197 (1450)	2976 (1350)	1543 (700)	1543 (700)	11023 (5000)
Height at max capacity	in (mm)	118.1 (3000)	114.2 (2900)	118.1 (3000)	118.1 (3000)	118.1 (3000)	118.1 (3000)
Height at max capacity with hooked-on sideshift	in (mm)	118.1 (3000)	118.1 (3000)	118.1 (3000)	118.1 (3000)	118.1 (3000)	118.1 (3000)

Full Visibility Triplex (FVT)		FVT 33
α - Mast/fork carriage tilt, forward	°	12
β - Mast/fork carriage tilt, backward	°	10
h1 - Mast lowered height	in (mm)	73.9 (1878)
h2 - Mast free lift	in (mm)	4.9 (124)
h3 - Mast lifting height	in (mm)	129.9 (3300)
h4 - Mast extended height	in (mm)	160.6 (4079)
Height at max capacity	in (mm)	98.4 (2500)



Head Office

B.P. 249 - 430 rue de l'Aubinière

44150 Ancenis Cedex - France

Tel: +33 (0)2 40 09 10 11 - Fax: +33 (0)2 40 09 10 97

www.manitou.com



This publication provides a description of the configuration versions and options for Manitou products, which may differ for equipment. The equipment presented in this brochure may be part of a series, as an option, or it may not be available, depending on the versions. Manitou reserves the right, at any time and without notice, to amend the specifications described and represented. The specifications provided do not bind the manufacturer. For more details, please contact your Manitou agent. This is not a contractually binding document. The presentation of the products is not contractually binding. List of specifications non-exhaustive. The logos as well as the visual identity of the company are owned by Manitou and cannot be used without authorisation. All rights reserved. The photos and diagrams contained in this brochure are only provided for consultation and information purposes.

MANITOU BF SA - Limited company with board of directors - Share capital: 39,668,399 euros - 857 802 508 RCS Nantes