

# RS6-42 M74

# RS



# GEHL®

Capacities		Metric	Imperial
Max. capacity		2993.71 kg	6600 lb
Max. lifting height		12.80 m	42 ft
Max. outreach		8.61 m	28 ft 3 in
Weight and dimensions			
Overall length to carriage	l1	5.81 m	19 ft 1 in
Overall width	b1	2.50 m	8 ft 2 in
Overall height	h17	2.39 m	7 ft 10 in
Wheelbase	y	3.05 m	10 ft
Ground clearance	m4	406.40 mm	16 in
Overall cab width	b4	838 mm	33 in
Tilt-up angle	a4	12 °	12 °
Tilt-down angle	a5	112 °	112 °
External turning radius	Wa3	4.17 m	13 ft 8 in
Unladen weight (with forks)		9979 kg	22000 lb
Unladen weight		9979 kg	22000 lb
Overall weight		9979.03 kg	22000 lb
Standard tyres		13 x 24	13 x 24
Forks length / width / section	l / e / s	1200 mm x 125 mm / 45 mm	47 in x 5 in / 2 in
Performances			
Lifting		11 s	11 s
Lowering		8 s	8 s
Extension		14 s	14 s
Retraction		12 s	12 s
Crowd		7 s	7 s
Dump		4 s	4 s
Engine			
Engine brand		Deutz	Deutz
Engine norm		Stage IV / Tier 4 Final	Stage IV / Tier 4 Final
Engine model		TCD 3.6 L4	TCD 3.6 L4
Number of cylinders / Capacity of cylinders		4 - 3.80 cm <sup>3</sup>	4 - 0.23 in <sup>3</sup>
Power (kW)		55 kW	55 kW
Max. torque / Engine rotation		390 Nm @ 1300 rpm	390 Nm @ 1300 rpm
Transmission			
Transmission type		Torque converter with powershift	Torque converter with powershift
Number of gears (forward / reverse)		4 / 3	4 / 3
Max. travel speed		24 km/h	15 mi/h
Parking brake		SAHR	SAHR
Service brake		Wet disc brakes	Wet disc brakes
Axle Manufacturer		Dana	Dana
Hydraulics			
Hydraulic pump type		Gear pump	Gear pump
Hydraulic flow / Pressure		157.09 l/min / 207 bar	157.09 l/min / 3002 PSI
Tank capacities			
Engine oil		14.70 l	4 US gal
Hydraulic oil		170 l	45 US gal
Fuel tank		177.90 l	47 US gal
Miscellaneous			
Steering wheels (front / rear)		2 / 2	2 / 2
Drive wheels (front / rear)		2 / 2	2 / 2
Safety cab homologation		ROPS/FOPS	ROPS/FOPS
Controls		Single joystick with FNR	Single joystick with FNR

# RS6-42 M74 - Load chart

## Load Chart imperial

## Load Chart Other Imperial

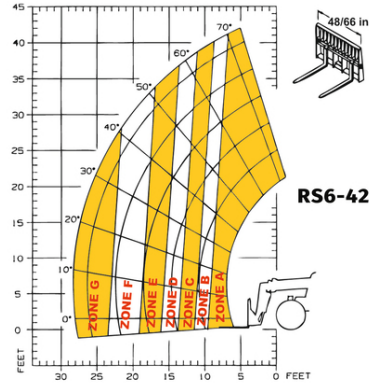
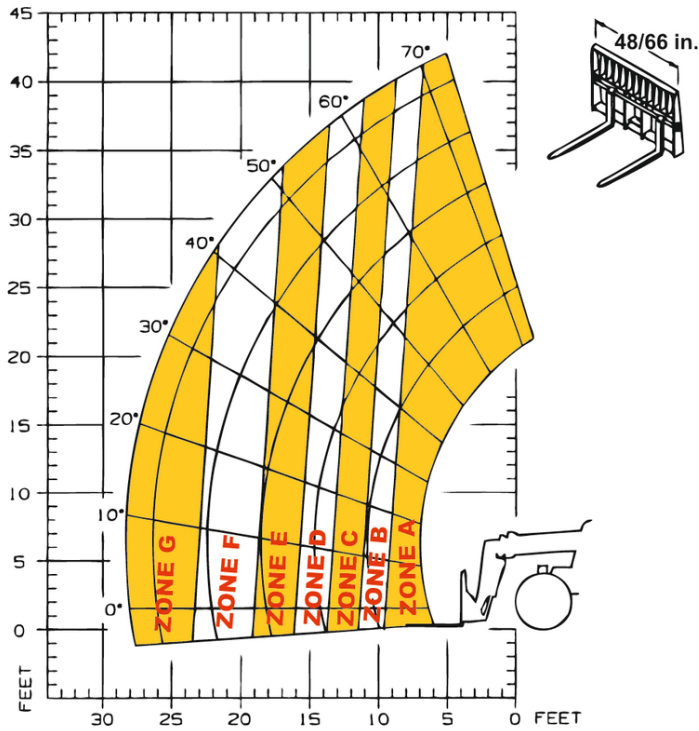

**RS6-42**

- ▲ A 6,600/6,600 lbs. (2994/2994 kg)
  - B 6,000/6,600 lbs. (2722/2994 kg)
  - C 5,000/6,000 lbs. (2268/2722 kg)
  - D 4,000/4,000 lbs. (1814/1814 kg)
  - E 3,000/4,000 lbs. (1361/1814 kg)
  - F 2,000/4,000 lbs. (907/1814 kg)
  - G 1,000/3,000 lbs. (454/1361 kg)
- outriggers up / optional outriggers down



# GEHL®

Siège Social

P.O. Box 179 - One Gehl Way - West Bend, WI, USA 53095

Tel: (262) 334-9461 - Fax: (262) 338-7517

[www.gehl.com](http://www.gehl.com)



This brochure describes versions and configuration options for Gehl products which may be fitted with different equipment. The equipment described in this brochure may be standard, optional or not available depending on version. Gehl reserves the right to change the specifications shown and described at any time and without prior warning. The manufacturer is not liable for the specifications given. For more information, contact your Gehl dealer. Non-contractual document. Product descriptions may differ from actual products. List of specifications is not comprehensive. The logos and visual identity of the company are the property of Gehl and may not be used without authorization. All rights reserved. The photos and diagrams contained in this brochure are provided for information only.

MANITOU EQUIPMENT AMERICAS, LLC - Limited company with board of directors - Share capital: 39,668,399 euros - 857 802 508 RCS West Bend